

EKLE'

DESIGN Cristian Feltrin

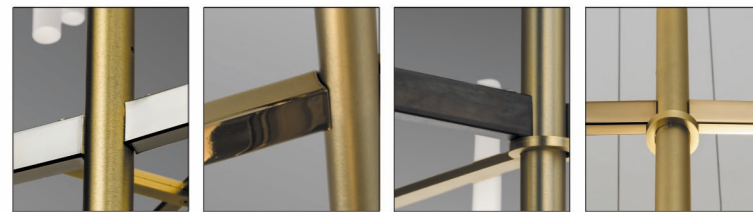

Oro spazzolato con pure steel
brushed gold with pure steel

Oro spazzolato con bronzo
brushed gold with bronze

Oro spazzolato con brunito corten
brushed gold with burnished corten

Oro spazzolato
brushed gold

Il telaio in metallo è disponibile nelle seguenti finiture:

- oro spazzolato con pure steel
- oro spazzolato con bronzo
- oro spazzolato con brunito corten
- oro spazzolato

Il diffusore è in plexiglass satinato.

Le lampade da tavolo, art. 668/1LP e art. 668/1LM sono ricaricabili tramite cavo USB incluso.

Le seguenti lampade sono dimmerabili: 668/20+16, 668/24, 668/20, 668/16, 668/12, 669/20,

The metal frame is available in the following finishes:



- brushed gold with pure steel
- brushed gold with bronze
- brushed gold with burnished corten
- brushed gold

The diffuser is in satin plexiglass.

The table lamps, art. 668 / 1LP and art. 668 / 1LM are rechargeable via the included USB cable.

The following lamps are dimmable: 668/20 + 16, 668/24, 668/20, 668/16, 668/12, 669/20, 670/20, 668 / 1LP, 668 / 1LM, 668 / 12P.

PLAFONIERA CEILING LAMP

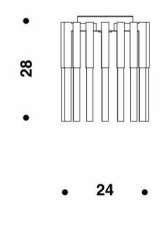
 <p>668/12PF 12 x LED 1,42W 2400 lumen - 3000K CE ⊕ ▽</p> <p>42</p> <p>39</p>	 <p>668/16PF 16 x LED 1,42W 3200 lumen - 3000K CE ⊕ ▽</p> <p>42</p> <p>50</p>	 <p>670/16PF 16 x LED 1,42W 3200 lumen - 3000K CE ⊕ ▽</p> <p>28</p> <p>24</p>
--	--	--

APPLIQUE WALL BRACKET

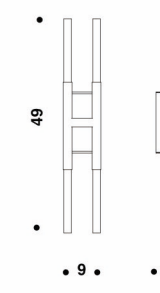
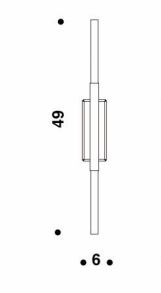
 <p>668/6A 6 x LED 1,42W 1200 lumen - 3000K CE ⊕ ▽</p> <p>64</p> <p>15 12</p>	 <p>668/4A 4 x LED 1,42W 800 lumen - 3000K CE ⊕ ▽</p> <p>49</p> <p>9 6</p>	 <p>668/2A 2 x LED 1,42W 400 lumen - 3000K CE ⊕ ▽</p> <p>49</p> <p>6 6</p>
---	--	--

LAMPADA DA TAVOLO TABLE LAMP

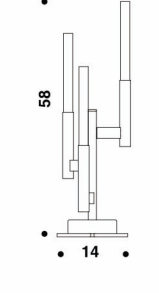
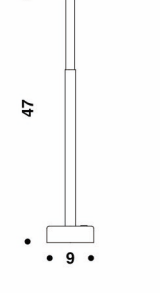
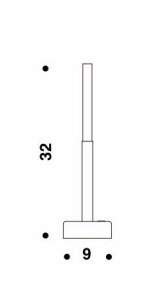
 <p>668/3L 3 x LED 1,42W 600 lumen - 3000K CE ⊕ ▽</p> <p>58</p> <p>14</p>	 <p>668/1LM 1 x LED 1,42W 200 lumen - 3000K CE ⊕ ▽</p> <p>47</p> <p>9</p>	 <p>668/1LP 1 x LED 1,42W 200 lumen - 3000K CE ⊕ ▽</p> <p>32</p> <p>9</p>
--	--	--

LAMPADA DA TERRA FLOOR LAMP

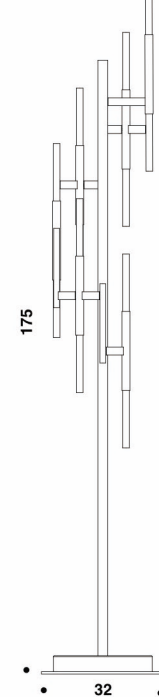
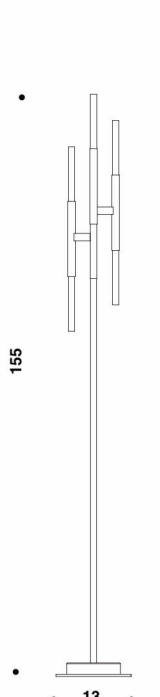
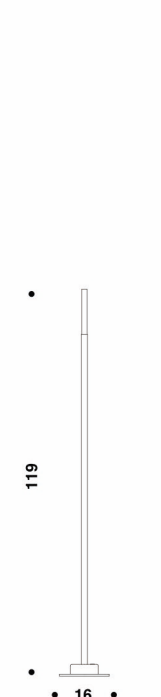
 <p>668/12P 12 x LED 1,42W 2400 lumen - 3000K CE ⊕ ▽</p> <p>175</p> <p>32</p>	 <p>668/6P 6 x LED 1,42W 1200 lumen - 3000K CE ⊕ ▽</p> <p>155</p> <p>13</p>	 <p>668/1P 1 x LED 1,42W 200 lumen - 3000K CE ⊕ ▽</p> <p>119</p> <p>16</p>
---	---	--

SOSPENSIONE SUSPENSION

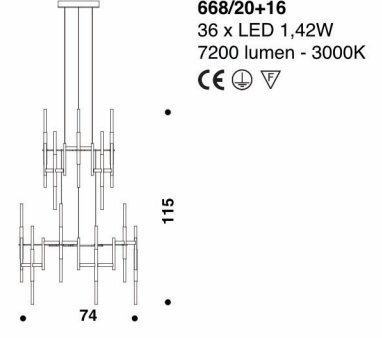
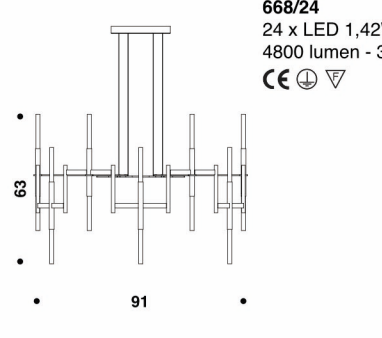
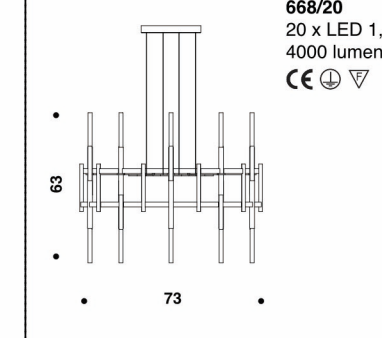
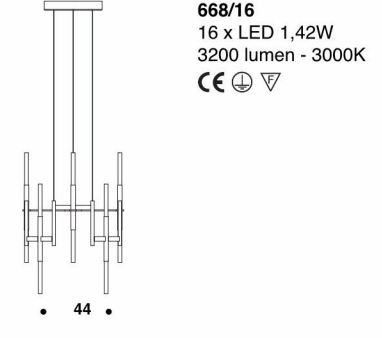
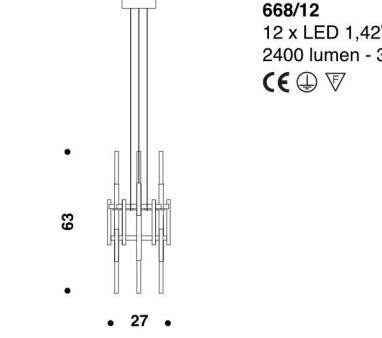
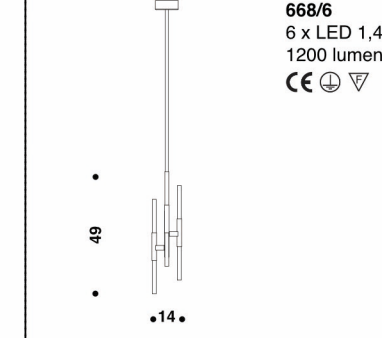
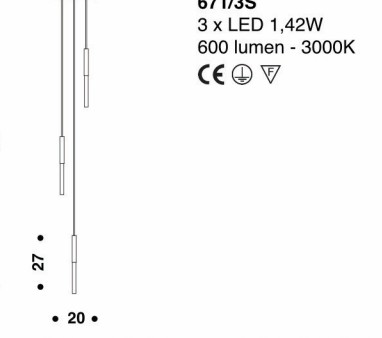
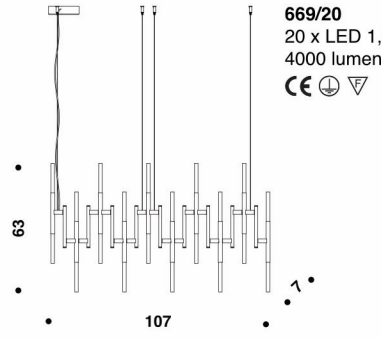
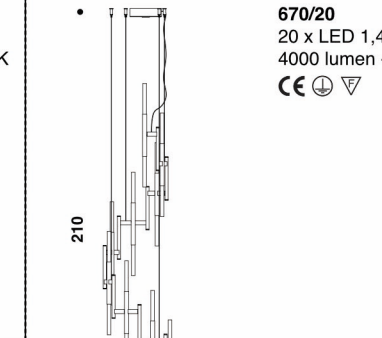
 <p>668/20+16 36 x LED 1,42W 7200 lumen - 3000K CE ⊕ ▽</p> <p>147</p> <p>115</p> <p>74</p>	 <p>668/24 24 x LED 1,42W 4800 lumen - 3000K CE ⊕ ▽</p> <p>63</p> <p>91</p>	 <p>668/20 20 x LED 1,42W 4000 lumen - 3000K CE ⊕ ▽</p> <p>63</p> <p>73</p>
 <p>668/16 16 x LED 1,42W 3200 lumen - 3000K CE ⊕ ▽</p> <p>63</p> <p>44</p>	 <p>668/12 12 x LED 1,42W 2400 lumen - 3000K CE ⊕ ▽</p> <p>63</p> <p>27</p>	 <p>668/6 6 x LED 1,42W 1200 lumen - 3000K CE ⊕ ▽</p> <p>49</p> <p>14</p>
 <p>671/3S 3 x LED 1,42W 600 lumen - 3000K CE ⊕ ▽</p> <p>111</p> <p>27</p> <p>20</p>	 <p>669/20 20 x LED 1,42W 4000 lumen - 3000K CE ⊕ ▽</p> <p>63</p> <p>107</p> <p>1</p>	 <p>670/20 20 x LED 1,42W 4000 lumen - 3000K CE ⊕ ▽</p> <p>210</p> <p>40</p>

Le finiture CORTEN (brunito) e ORO ANTICO, è un procedimento di ossidazione naturale. La realizzazione di tale processo è influenzata dal livello di umidità, dalla temperatura esterna e da altre variabili ambientali. La mano dell'uomo e la specifica lavorazione sono il valore aggiunto che testimonia l'autentico 'Made in Italy'.

Come tutte le opere dove il procedimento non è meccanico ma artigianale le eventuali variazioni di colore non sono da considerarsi un difetto ma una testimonianza dell'unicità del prodotto. Le finiture Corten e Oro antico rendono quindi il prodotto unico e irripetibile. Le foto presenti nel nostro catalogo costituiscono solo un'identificazione del tipo di prodotto e non rappresentano un campione degli stessi.

The finishes CORTEN (burnished) and ANTIQUE GOLD are the result of a procedure of natural oxidation. The procedure is every time affected by the percentage of humidity in the air, by the external temperature and by other environmental variables. Hands of man and a special processing are a value added, which is evidence of the real 'Made in Italy'.

As in all works where the procedure is not mechanical but handcrafted, variations are possible, but they must not be considered as a defect, but rather as a proof of the uniqueness of the product. The Corten and Antique gold finishes makes the product as unique, since every results is not reproducible in identical way. The pictures of our catalogues are only an example of the kind of the product, but they cannot be considered strictly as samples of them, since the result can be different.